

Campanas UFO Next

UFO Next LED Highbays

GARANTÍA 5 AÑOS
5 YEARS WARRANTY



DESCRIPCIÓN - DESCRIPTION

Campanas LED UFO disponibles en 150W y 200W de potencia con temperatura de color 5000K. Ideal para iluminación industrial. Regulable 1-10V. Clase de eficiencia energética B.

UFO LED high bays available in 150W and 200W power with 5000K color temperature. Ideal for industrial lighting. Dimmable 1-10V. Energy efficiency class B.

ENLACES RELACIONADOS - RELATED LINKS

- [Declaración de conformidad CE / CE Declaration of Conformity \(ES\), \(EN\)](#)
- [Manual de Instrucciones \(ES\)](#)
- [ISO 9001](#)
- [ISO 14001](#)

GARANTÍA - WARRANTY

ALG le ofrece una garantía de **5 años** desde la fecha de compra.

ALG offers you a 5-year warranty from the date of purchase.



ALG dispone de un Sistema de Gestión de la Calidad según la norma ISO 9001 desde 1998 y desde el año 2021 estamos certificados con la norma 14001 para mejor conservación y protección del Medio Ambiente

ALG has a Quality Management System according to the ISO 9001 standard since 1998 and since 2021 we have been certified with the 14001 standard for better conservation and protection of the Environment.

INFORMACIÓN TÉCNICA · TECHNICAL INFORMATION

DATOS COMERCIALES / COMMERCIAL DATA

CODE	67699	67730
REFERENCE	CAMPANA UFO NEXT 150W 50K	CAMPANA UFO NEXT 200W 50K

DATOS ELECTRICOS / ELECTRICAL DATA

INPUT VOLTAGE	220-240V	220-240V
FREQUENCY	50Hz	50Hz
POWER	150W	200W
POWER FACTOR	0,98	0,99
FLICKER (PST LM)	<0,04	<0,04
IEC PROTECTION	Class I	Class I

DATOS FOTOMÉTRICOS / PHOTOMETRIC DATA

EFFICACY (LM/W)	160lm/W	160lm/W
LUMINOUS FLUX (LM)	24000lm	32000lm
CCT (KELVIN)	5000K	5000K
CRI	80	80
BEAM ANGLE	120°	120°
LUMEN MAINTENANCE FACTOR	L80B50>50000H	L80B50>50000H

VIDA ÚTIL Y MEDIO AMBIENTE / LIFESPAN & ENVIRONMENTAL DATA

ENERGY CLASS	B	B
CONSUMPTION	150kWh/1000h	200kWh/1000h
LIFESPAN	50000h	50000h
ON/OFF CICLES	25000	25000
WORKING TEMP.	-20°C~+50°C	-20°C~+50°C

FUENTE DE ALIMENTACIÓN / DRIVER

DRIVER BRAND	SOSEN	SOSEN
DIMMABLE	1-10V	1-10V
SURGE PROTECTION	6KV	6KV

CARACTERÍSTICAS FÍSICAS / PHYSICAL CHARACTERISTICS

SIZE	Ø235*161mm	Ø265*165mm
COLOR	Negro · Black · Noir	Negro · Black · Noir
WEIGHT	2,5kg	2,9kg
IP PROTECTION	IP65	IP65
IK PROTECTION	IK07	IK07
BODY MATERIAL	ALUMINIUM	ALUMINIUM
DIFFUSER MATERIAL	PC	PC

EMBALAJE / PACKAGING

CODE	67699	67730
REFERENCE	CAMPANA UFO NEXT 150W 50K	CAMPANA UFO NEXT 200W 50K
UNITS OUTER BOX	1	1
SIZE OF BOX	L285*W285*H170mm	L315*W315*H180mm
GROSS WEIGHT	3,1KG	3,8KG

DIMENSIONES - SIZE

150W

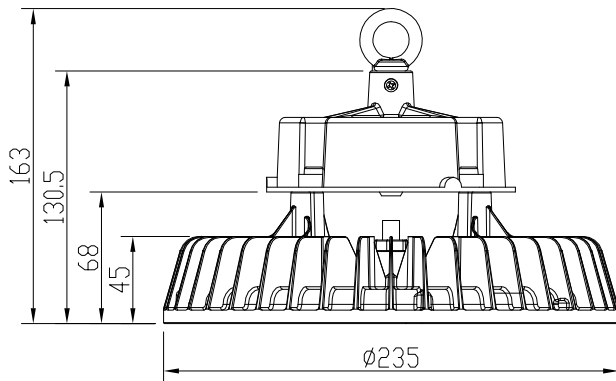

200W

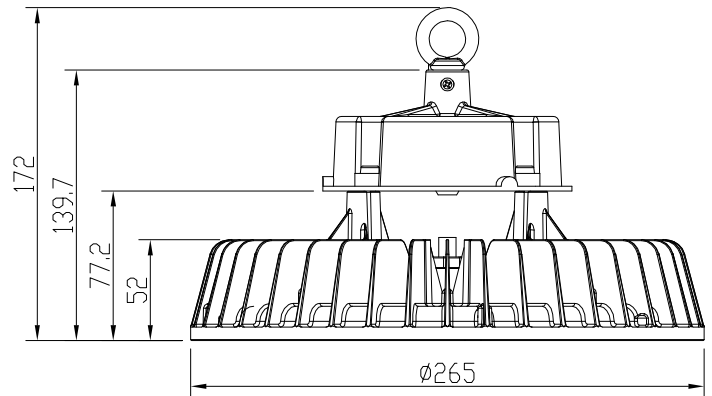

DISTRIBUCIÓN LUMÍNICA - LIGHT DISTRIBUTION DIAGRAM

150W

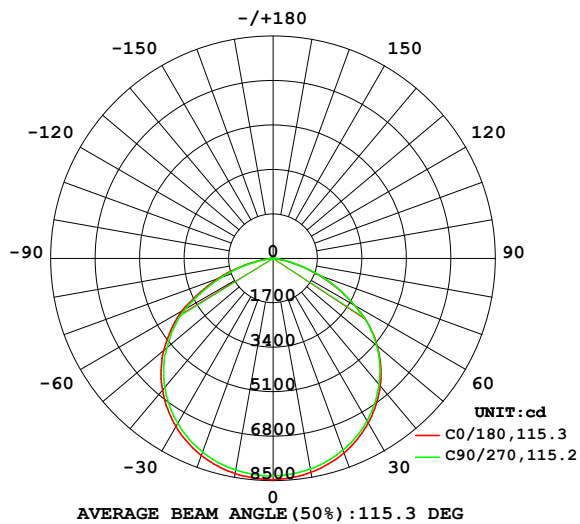

200W

