

Proyectores Serie Efficiency

Efficiency Floodlights

GARANTÍA 3 AÑOS
3 YEARS WARRANTY



DESCRIPCIÓN - DESCRIPTION

Directos a 230V, con el driver integrado. Disponibles en 150W y 200W, en luz fría 6000K. Con un grado de protección de IP65 son perfectos para su uso en exteriores.

It works directly to the network, at 230V. Available in 150W, and 200W power. Cold light 6000K. Suitable for outdoors thanks to its IP65 protection.

ENLACES RELACIONADOS - RELATED LINKS

- [Declaración de conformidad CE](#)
- [Certificado ISO 9001](#)
- [Certificado ISO 14001](#)

GARANTÍA - WARRANTY

ALG le ofrece una garantía de **3 años** desde la fecha de compra.

ALG offers you a 3-year warranty from the date of purchase.



ALG dispone de un Sistema de Gestión de la Calidad según la norma ISO 9001 desde 1998 y desde el año 2001 estamos certificados con la norma 14001 para mejor conservación y protección del Medio Ambiente

ALG has a Quality Management System according to the ISO 9001 standard since 1998 and since 2001 we have been certified with the 14001 standard for better conservation and protection of the Environment.

INFORMACIÓN TÉCNICA - TECHNICAL INFORMATION

DATOS COMERCIALES / COMMERCIAL DATA

CODE	67404	67408
REFERENCE	PROYECTOR EF 150W 60K	PROYECTOR EF 200W 60K

DATOS ELECTRICOS / ELECTRICAL DATA

INPUT VOLTAGE	220-240V	220-240V
FREQUENCY	50Hz	50Hz
POWER	150W	200W
POWER FACTOR	0,98	0,98
IEC PROTECTION	Class I	Class I

DATOS FOTOMÉTRICOS / PHOTOMETRIC DATA

EFFICACY (LM/W)	140lm/W	140lm/W
LUMINOUS FLUX (LM)	21000lm	28000lm
CCT (KELVIN)	6000K	6000K
CRI	70	70
BEAM ANGLE	110°	110°

CHIP DE LED / LED CHIP

LED TYPE	SMD 2835	SMD 2835
BRAND	SAMSUNG	SAMSUNG

VIDA ÚTIL Y MEDIO AMBIENTE / LIFESPAN & ENVIRONMENTAL DATA

ENERGY CLASS	C	C
CONSUMPTION	150kWh/1000h	200kWh/1000h
LIFESPAN	50000h	50000h
WORKING TEMP.	-20°C~+40°C	-20°C~+40°C

FUENTE DE ALIMENTACIÓN / DRIVER

DIMMABLE	NO	NO
SURGE PROTECTION	1/2kV	1/2kV

CARACTERÍSTICAS FÍSICAS / PHYSICAL CHARACTERISTICS

SIZE	318,5x390X55mm	371x458,5X57mm
WEIGHT	2,9kg	3,7kg
IP PROTECTION	IP65	IP65
IK PROTECTION	IK05	IK05
BODY	ALUMINIUM	ALUMINIUM
DIFFUSER	GLASS	GLASS

EMBALAJE / PACKAGING

CODE	67404	67408
REFERENCE	PROYECTOR EF 150W 60K	PROYECTOR EF 200W 60K
UNITS	1	1
SIZE OF INDIVIDUAL BOX	323*60*395mm	376*62*463mm
GROSS WEIGHT	3.02kgs	4.05kgs

DIMENSIONES - SIZE

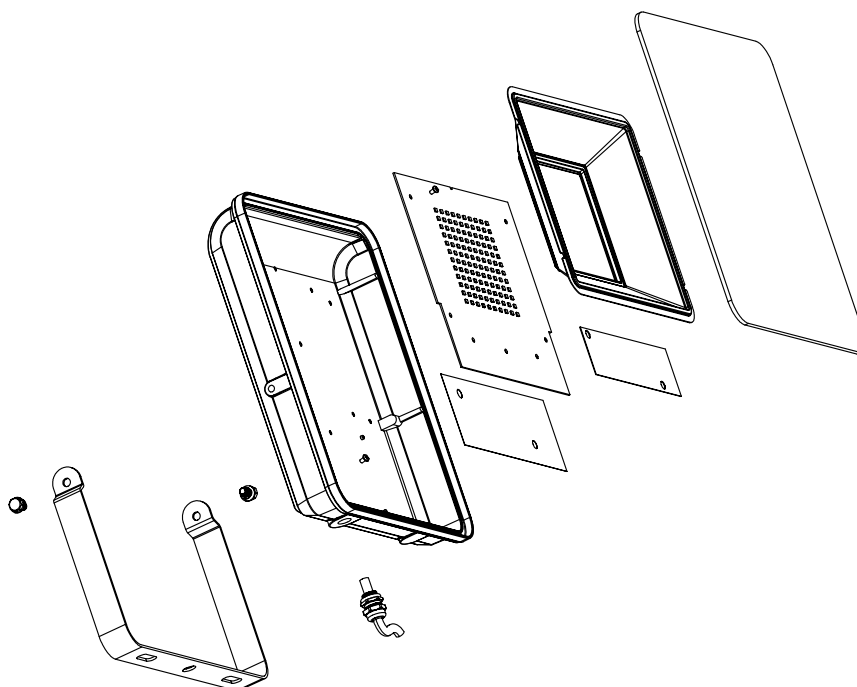
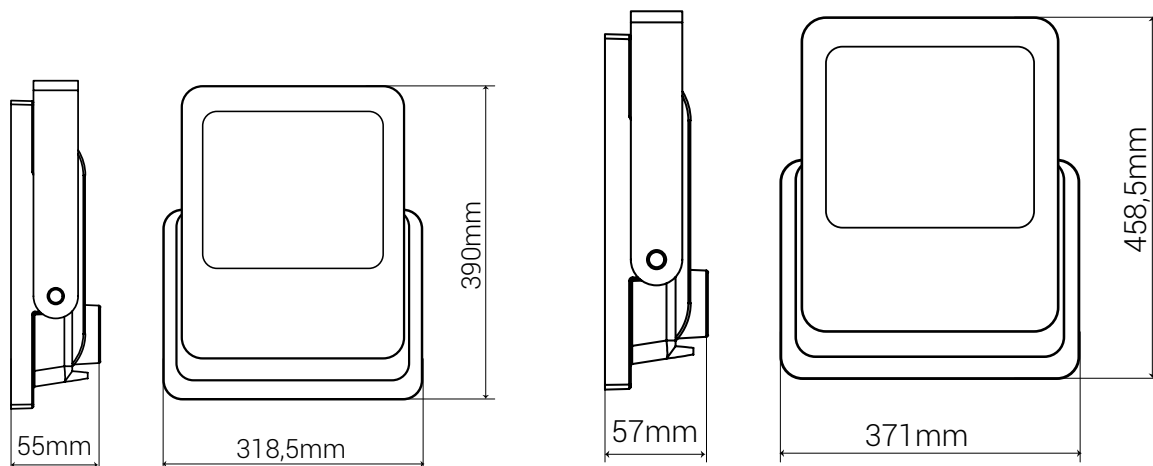

DISTRIBUCIÓN LUMÍNICA - LIGHT DISTRIBUTION

